

# Daken

**DKMM 155, 175**

**Operator's Manual**



<b>Important Safety Information</b> .....	
Safety at All Times .....	
Look For The Safety Alert Symbol .....	
Safety Labels .....	
<b>Introduction</b> .....	
Application .....	
Using This Manual .....	
Terminology .....	
Definitions .....	
Owner Assistance .....	
Serial Number Plate .....	
<b>Section 1: Assembly and Set-up</b> .....	
Tractor Requirements .....	
Assembly .....	
Tractor Hook-Up .....	
Driveline Installation .....	
<b>Section 2: Operating Instructions</b> .....	
Transporting .....	
Mowing Instructions .....	
Operating Instructions .....	
<b>Section 3: Adjustments</b> .....	
Leveling the Mower .....	
Cutting Height Adjustment .....	
3-Point Hitch Adjustments .....	
Belt Tension .....	
<b>Section 4: Maintenance and Lubrication</b> .....	
Maintenance .....	
Knife Replacement .....	
V-Belt Installation .....	
Storage .....	
Lubrication .....	
Driveline Shaft U-Joints .....	
Roller Bearing (Both Ends) .....	
Cutter Rotor Bearing (Both Ends) .....	
Gearbox .....	
Driveline Profiles .....	
<b>Section 5: Specifications &amp; Capacities</b> .....	
<b>Section 6: Troubleshooting</b> .....	
<b>Section 7: Appendix</b> .....	
Bolt Torque .....	
Warranty .....	
<b>Section 8: Parts illustration</b> .....	

# Important Safety information

## Safety at all times

Thoroughly read and understand the instructions given in this manual before operation. Refer to the “Safety Decal”, read all instructions noted on them.

**Do not allow anyone to operate this equipment who has not fully read and comprehended this manual and who has not been properly trained in the safe operation of the equipment.**

- Operator should be familiar with all functions of the unit.
- Operate implement from the driver’s seat only.
- Make sure all guards and shields are in place and secured before operating the implement.
- Do not leave tractor or implement unattended with engine running.
- Dismounting from a moving tractor could cause serious injury or death.
- Do not stand between tractor and implement during hitching.
- Keep hands, feet, and clothing away from power-driven parts.
- Wear snug fitting clothing to avoid entanglement with moving parts.
- Watch out for wires, trees, etc., when raising implement. Make sure all persons are clear of working area.
- Turning tractor too tight may cause implement to ride up on wheels. This could result in injury or equipment damage.

## Look For The Safety Alert Symbol

The SAFETY ALERT SYMBOL indicates there is a potential hazard to personal safety involved and extra safety precaution must be taken. When you see this symbol, be alert and carefully read the message that follows it. In addition to design and configuration of equipment, hazard control and accident prevention are dependent upon the awareness, concern, prudence and proper training of personnel involved in the operation, transport, maintenance and storage of equipment.

### Be aware of signal words

A signal word designates a degree or level of hazard seriousness. The signal words are:



### DANGER

Indicates an imminently hazardous situation which, if not avoided, will result in death or serious injury. This signal word is limited to the most extreme situations, typically for machine components that, for functional purpose, cannot be guarded.



### WARNING

Indicates a potentially hazardous situation which, if not avoided, could result in death or serious injury, and includes hazards that are exposed when guards are removed. It may also be used to alert against unsafe practices.



### CAUTION

Indicates a potentially hazardous situation which, if not avoided, may result in minor or moderate injury. It may also be used to alert against unsafe practices.

## For you protection

- Thoroughly read and understand the “safety label” section, read all instructions noted on them.

## Shutdown and storage

- Lower machine to ground, put tractor in park, turn off engine, and remove the ignition key.
- Detach and store implements in a area where children normally do not play. Secure implement by using blocks and supports.

## Use safety lights and devices

- Slow moving tractors, self-propelled equipment, and towed implements can create a hazard when driven on public roads. They are difficult to see, especially at night.
- Flashing warning lights and turn signals are recommended whenever driving on public roads. Use lights and devices provided with implement.

## Transport machinery safely

- Comply with state and local laws.
- Maximum transport speed for implement is 20km/h. Do not exceed. Never travel at a speed which does not allow adequate control of steering and stopping. Some rough terrain require a slower speed.
- Sudden braking can cause a towed load to swerve and upset. Reduce speed if towed load is not equipped with brakes.
- Use the following maximum speed - tow load weight ratios as a guideline:  
**30km/h** when weight is less than or equal to the weight of tractor.  
**15km/h** when weight is double the weight of tractor.
- **IMPORTANT:** Do not tow a load that is more than double the weight of tractor.

## Keep riders off machinery

- Riders obstruct of operator's view, they could be struck by foreign objects or thrown from the machine.
- Never allow children to operate equipment.

## Practice safe maintenance

- Understand procedure before doing work. Use proper tools and equipment. refer to Operator's Manual for additional information.
- Work in a clean dry area.
- Lower the implement to the ground, put tractor in park, turn off engine, and remove key before performing maintenance.
- Allow implement to cool completely.
- Do not grease or oil implement while it is operation.
- Inspect all parts. Make sure parts are in good condition and installed properly.
- Remove buildup of grease, oil or debris.
- Remove all tools and unused parts from implement before operation.

## Prepare for emergencies

- Be prepared if a fire starts.
- Keep a fist aid kit and fire extinguisher handy.
- Keep emergency numbers for doctor, ambulance, hospital and fire department near phone.

## Wear protective equipment

- Protective clothing and equipment should be worn.
- Wear clothing and equipment appropriate for the job. Avoid loose fitting clothing.
- Prolonged exposure to loud noise can cause hearing impairment or hearing loss. Wear suitable hearing protection such as earmuffs or earplugs.
- Operating equipment safely requires the full attention of the operator. Avoid wearing radio headphones while operating machinery.

## **Avoid high pressure fluids hazard**

- Escaping fluid under pressure can penetrate the skin causing serious injury.
- Avoid the hazard by relieving pressure before disconnecting hydraulic lines.
- Use a piece of paper or cardboard, not body parts, to check for suspected leaks. Wear protective gloves and safety glasses or goggles when working with hydraulic systems.
- If an accident occurs, see a doctor immediately. Any fluid injected into the skin must be treated within a few hours or gangrene may result.

## **Safety Labels**

Your Flail Mower comes equipped with all safety labels in place. They were designed to help you safely operate your implement. Read and follow their directions.

1. Keep all safety labels clean and legible.
2. Replace all damaged or missing labels. To order new labels go to your nearest Daken dealer.
3. Some new equipment installed during repair requires safety labels to be affixed to the replaced component as specified by Daken. When ordering new components make sure the correct safety labels are included in the request.
4. Refer to this section for proper label placement.  
To install new labels:
  - a. Clean the area the label is to be placed.
  - b. Spray soapy water on the surface where the label is to be placed.
  - c. Peel backing from label. Press firmly onto the surface.
  - d. Squeeze out air bubbles with the edge of a credit card.

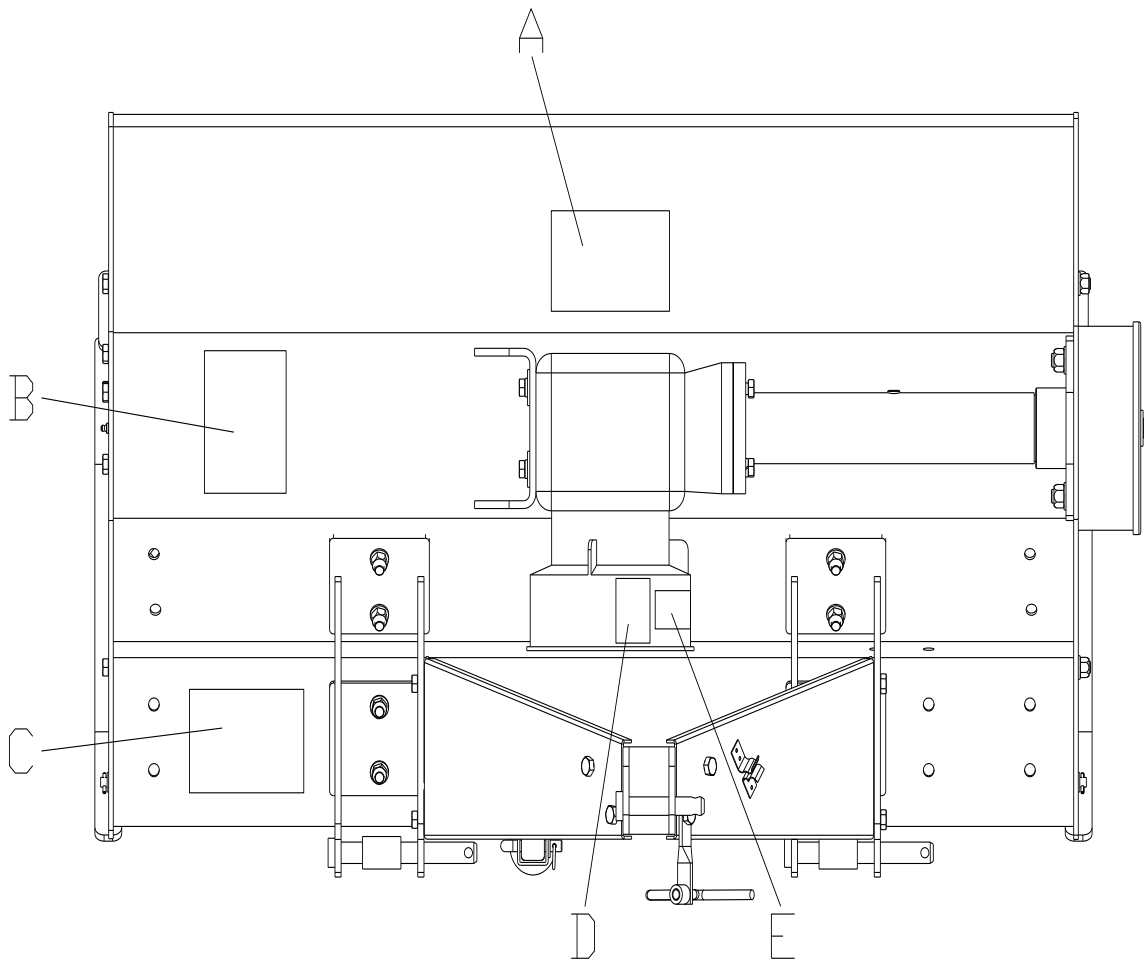

A



B



C



D



E





# Introduction

This implement has been designed with care and built by skilled workers using quality materials. Proper assembly, maintenance, and safe operating practices will help you get years of satisfactory use from the machine.

## Application

The Flail Mowers are designed for Category 1 - three point hitch or Quick-Hitch System mounting. These Flail Mowers/Mulchers are designed for cutting grasses, weeds, light undergrowth and breaking up branches up to 50mm in diameter, on farm, hobby farm, parks and gardens. It is not designed to cut rocks, stumps or as a cultivator.

## Using This Manual

- This Operator's Manual is designed to help familiarize you with safety, assembly, operation, adjustments, troubleshooting, and maintenance. Read this manual and follow the recommendations to help ensure safe and efficient operation.
- The information contained within this manual was current at the time of printing. Some parts may change slightly to assure you of the best performance.
- To order a new Operator's or Parts Manual contact your authorized Daken dealer.

## Terminology

"Right" or "Left" as used in this manual is determined by facing the direction the machine will operate while in use unless otherwise stated.

## Definitions

**Note** : A special point of information that the operator must be aware of before continuing.

**Important** : A special point of information related to its preceding topic. The intention is that this information should be read and noted before continuing.

## Owner Assistance

The Warranty Registration card should be filled out by the dealer at the time of purchase. This information is necessary to provide you with quality customer service. If customer service or repair parts are required contact a dealer. A dealer has trained personnel, repair parts and equipment needed to service the machine.

The parts on your machine have been specially designed and should only be replaced with genuine parts.

## Serial Number Plate

For prompt service always use the serial number and model number when ordering parts from your dealer. Be sure to include your serial and model numbers in correspondence also.

## Section 1: Assembly and Set-up

### Tractor Requirements

This mower is designed with a 3-Point category I hitch. Tractor horse power rating should not exceed 55 PTO horse power.

## Assembly

Refer to the parts illustration.

### Tractor Hook-Up

1. Be certain that tractor draw bar will not interfere. Move draw bar ahead or remove if required. Draw bar should also be checked for clearance when unit is being raised for the first time.
2. Align lower link arms of tractor to hitch clevises on mower. Insert lower hitch pins into lower ball swivels and attach linch pins.
3. Attach tractor top link to upper floating hitch on mower with pin supplied. Secure with lock pin.
4. Adjust tractor top link in or out to place upper hitch pin vertically above or slightly behind lower hitch pins to allow mower flotation. The mower should be run with the back 15 degrees lower than the front.

### Driveline Installation

1. Slide driveline end with extended safety cone over splined shaft of gearbox and secure with attaching device.
2. Slide driveline over tractor's splined PTO shaft and secure with locking device of driveline.
3. Driveline should now be moved back and forth to insure that it is secure on the PTO shaft of the tractor and mower gearbox.
4. Attach chain from the driveline shield to one of the upper hitch braces to ensure that the shield does not rotate.
5. **Should driveline require shortening:**
  - a. Hold the half-shafts next to each other in the shortest working position and mark them.
  - b. Shorten inner and outer guard tubes equally.
  - c. Shorten inner and outer sliding profiles by the same length as the guard tubes.
  - d. Proper overlap is a minimum of one-half the length of each tube, with both tubes being of equal length.
  - e. Round off all sharp edges and remove burrs. Grease sliding profiles.



### CAUTION

Tractor PTO shield and all mower guards must be in place at all times during operation!

## Section 2: Operating Instructions

### Transporting

**NOTE:** Always disengage PTO before raising mower to transport position.

1. When raising the mower to transport position, be sure that driveline does not contact tractor or mower. Adjust and set the tractor's 3-point hitch lift height so that the driveline does not contact mower deck in the fully raised position.
2. Be sure to reduce tractor ground speed when turning, leaving enough clearance so that the mower does not contact obstacles such as buildings, trees or fences.
3. Select a safe ground travel speed when transporting from one area to another. When traveling on roadways, transport in such a way that faster moving vehicles may pass safely.
4. When traveling over rough or hilly terrain, shift tractor to a lower gear.



### CAUTION

When traveling on public roads, whether at night or during the day, use accessory lights and devices for adequate warning to operators of other vehicles. Comply with all Federal, State, and local laws.

## Mowing Instructions

1. Clear area to be mowed of objects and debris that might be picked up and thrown by the mower blades.
2. Grass is best cut when it is dry. Mowing wet grass can cause plugging resulting in grass clumps behind the mower.
3. Grass should be mowed frequently as shorter clippings deteriorate faster.
4. If mowing extremely tall grass, it is best to raise cutting height and mow the area, then lower cutting height and mow a second time at the desired height.

## Operating Instructions

Proper servicing and adjustments are the key to the long life of any machine. With careful and systematic

inspection of the mower, costly maintenance, time and repair can be avoided.

Before beginning to mow, the following inspection should be performed:

1. Check oil level in gearbox.
2. Check that all plugs in gearbox have been replaced and tightened properly.
3. Be sure all mower knives, bolts and nuts are tight.
4. Be certain all guards and shields are in place and secure.
5. **Grease driveline shaft and all other grease fittings.**
6. Clear area to be mowed of rocks, branches and other foreign objects.
7. Lower mower to ground. Set tractor throttle to just above idle. Engage PTO to start blades rotating.
8. Slowly bring the RPM,s up to a maximum of 540RPM.
9. At first begin mowing at a slow forward speed and shift up until the desired speed is achieved - maintaining 540 PTO rpm.
10. Mower knives will cut better at a faster blade speed than at reduced throttle.
11. After mowing the first 50 feet, stop and check to see that the mower is adjusted properly.
12. **Do not** make sharp turns or attempt to back up while mower is on the ground. Raise the machine of the ground if turning, this will prevent roller and body damage.
13. **Do not** engage PTO with mower in the fully raised position. **Do not** engage PTO at full throttle.
14. The gearbox has an over run included, so when the pto is disengaged the rotor will still be spinning, take caution that it has stopped before doing anything with the machine

## Section 3: Adjustments

### Leveling the Mower

**NOTE:** Tractor and mower should be on level ground.

Leveling can be adjusted at the tractor's 3-point arms and center link.

### Cutting Height Adjustment

The machines cutting height depends upon the position of the rear roller.

1. Remove the bolts that fix the roller on both sides.
2. Lift or lower both sides of roller in equal measurements.
3. Replace bolts and re-tighten.

### 3-Point Hitch Adjustments

The 3-point hitch system on this mower has been designed for front to back flotation when mowing on uneven terrain. Adjust tractor's top center link to place the upper hitch pin vertically above or slightly behind the lower hitch pins. The mower should be run with the back 15 degrees lower than the front.

The hitch can also be adjusted from side to side by turning the adjustment handle. Turn handle until you have

achieved your desired location.



## CAUTION

Engage parking brake, shut off tractor, remove key and disengage PTO before making any height adjustments!

## Belt Tension



## CAUTION

Belt drive system under spring tension; use care to avoid bodily harm!

The Belt tension should be checked after the first 20 hours of use. And then every 40 hours of use.

1. Tension on the belt can be adjusted with the belt tension bolt. Turn the bolt until desired tension is achieved. When the belt has the correct tension the gearbox should be adjusted so that the gearbox extension is running straight (parallel) with the flail mower. Loosen bolts at the bottom of the gearbox and move gearbox until gearbox extension is running straight.
2. Excessive tension on the belt may lead to premature failure of belt and drive components.



## CAUTION

Excessive tension on the belt may lead to premature failure of belt and drive components. Excessive tension on the belt may also lead to a safety hazard to the operator or bystanders.

## Section 4: Maintenance and Lubrication

### Maintenance

Proper servicing and adjustment is the key to the long life of any farm implement. With careful and systematic inspection, you can avoid costly maintenance, time and repair.



## CAUTION

For safety reasons, each maintenance operation must be performed with tractor PTO disengaged, mower lowered completely to ground and tractor engine shut off with ignition key removed.

- After using the mower for several hours, check all bolts to be sure they are tight and check drive belt tension.
- Replace any worn, damaged or illegible safety decals by obtaining new decals from dealer.

### Knife Replacement

**IMPORTANT:** Make sure that the knife is the same length as the others on the mower. This will keep the rotor rotation balanced.

1. Remove bolt and nut.
2. Remove old knife.
3. Install new knife and existing bolt.
4. Secure with nut.

### V-Belt Installation



## CAUTION

Belt drive system under spring tension; use care to avoid bodily harm!

1. Remove belt guard fender and belt cover.
2. Disengage belt tension by loosening belt tension bolt until belt can be removed.
3. With tension relieved from belt remove old belt from pulleys.
4. Tighten belt tension bolt.
5. Reinstall belt guard and belt guard fender.

## Storage

At the end of the working season or when the mower will not be used for a long period, it is good practice to clean off any dirt or grease that may have accumulated on the mower and any of moving parts.

1. Clean as necessary.
2. Check knives for wear and replace if necessary.
3. Inspect mower for loose, damaged or worn parts and adjust or replace as needed.
4. Store unit inside if possible for longer life.
5. Repaint parts where paint is worn or scratched to prevent rust.
6. Replace all damaged or missing decals.

## Lubrication

### Driveline Shaft U-Joints



Type of Lubrication: Multi-purpose Grease

### Roller Bearing (Both Ends)



Type of Lubrication: Multi-purpose Grease

### Cutter Rotor Bearing (Both Ends)



Type of Lubrication: Multi-purpose Grease

### Gearbox



Type of Lubrication: SAE 90W Gear Lube

Check oil level in gearbox by removing the plug located on the right hand side. Oil should be level with

bottom of plug hole. Add oil if necessary by removing top fill plug and side plug. Add oil until it flows from side plug hole.

**Do not overfill!**

**IMPORTANT:** Mower should be level when checking oil in gearbox!

## Driveline Profiles



Type of Lubrication: Multi-purpose Grease

## Section 5: Specifications & Capacities

MODEL	DKMM 155	DKMM 175
DIMENSIONS(L*W*H)	1665*790*850mm	1865*790*850mm
STRUCTURE WEIGHT	340Kg	370Kg
CUTTING WIDTH	1.52m	1.72m
WORKING EFFICIENCY	4900-13000m <sup>2</sup> /h	5500-14400m <sup>2</sup> /h
PTO TURNING SPEED	540r/min	540r/min
PTO SPLINE	6*8*800mm	6*8*800mm
POWER REQUIRED	30-40HP	40-50HP

## Section 6: Troubleshooting

Problem	Solution
 <b>CAUTION</b> Do not try to clean rear discharge area when mower is running. Bodily harm may occur!	
<b>Belt slipping</b>	Unplug and clean mower deck.
	Remove belt guard shields and clean sheaves.
	Replace belt.
<b>Patches of uncut grass</b>	Mow at full throttle (540 PTO rpm), check PTO speed and tractor engine.
	Shift transmission to a lower gear.
	Tighten belts.
<b>Excessive vibration</b>	Replace missing knives.
	Replace knives.
	Replace drive belt.
	Replace pulleys or align.
<b>Gearbox noisy</b>	Remove belt guard shields & clean debris from belt area & sheaves.
	Check lubricant level.
<b>Knives scalping grass</b>	Raise cutting height by adjusting roller.
	Change mowing pattern.
	Reduce speed turns.
<b>Uneven cut</b>	Shift to a lower gear.
	Level mower.
	Replace missing knives.

<b>Tractor loaded down by mower</b>	Mow at full throttle (540 PTO rpm).
	Shift to a lower gear.
	Clean mower.

## Section 7: Appendix

### Bolt Torque

The tables shown below give correct torque values for various bolts and cap screws. Tighten all bolts to the torques specified unless otherwise noted. Check tightness of bolts periodically, using bolt torque chart as a guide. Replace hardware with the same strength bolt.

#### ENGLISH TORQUE SPECIFICATIONS

Bolt Diameter	Bolt Torque					
	SAE 2		SAE 5		SAE 8	
	N.m	lb-ft	N.m	lb-ft	N.m	lb-ft
1/4"	8	6	12	9	17	12
5/16"	13	10	25	19	36	27
3/8"	27	20	45	33	63	45
7/16"	41	30	72	53	100	75
1/2"	61	45	110	80	155	115
9/16"	95	60	155	115	200	165
5/8"	128	95	215	160	305	220
3/4"	225	165	390	290	540	400
7/8"	230	170	570	420	880	650

#### METRIC TORQUE SPECIFICATIONS

Bolt Diameter	Bolt Torque			
	8.8		10.9	
	N.m	lb-ft	N.m	lb-ft
M3	0.5	0.4	1.8	1.3
M4	3	2.2	4.5	3.3
M5	6	4	9	7
M6	10	7	15	11
M8	25	18	35	26
M10	50	37	70	52
M12	90	66	125	92
M14	140	103	200	148
M16	225	166	310	229
M20	435	321	610	450
M24	750	553	1050	744
M30	1495	1103	2100	1550
M36	2600	1917	3675	2710

Torque figures indicated above are valid for non-greased or non-oiled threads and heads otherwise specified. Therefore, do not grease or oil bolts or cap screws unless otherwise specified in this manual. When using locking elements, increase torque values by 5%.

## Warranty

Daken warrants to the original purchaser that this product will be free from defects in material and workmanship beginning on the date of purchase by the end user according to the following schedule when used as intended and under normal service and conditions for personal use.

**Overall Unit and Driveline:** One year Parts and Labor

**Gearbox:** One year on all components.

**Blades and Belts:** Considered wear items.

This warranty is limited to the replacement of any defective part by manufacturer and the installation by the dealer of any such replacement part, and does not cover common wear items such as blades, belts, tines, etc. Daken reserves the right to inspect any equipment or parts which are claimed to have been defective in material or workmanship.

This warranty does not apply to any part or product which in Daken judgment shall have been misused or damaged by accident or lack of normal maintenance or care, or which has been repaired or altered in a way which adversely affects its performance or reliability, or which has been used for a purpose for which the product not designed. Misuse also specifically includes failure to properly maintain oil levels, grease points, and driveline shafts.

Claims under this warranty must be made to the dealer which originally sold the product and all warranty adjustments must be made through such dealer. Daken reserves the right to make changes in materials or design of the product at any time without notices.

This warranty shall not be interpreted to render Daken liable for damages of any kind, direct, consequential, or contingent to property. Furthermore, Daken shall not be liable for damages resulting from any cause beyond its reasonable control. This warranty does not extend to loss of crops, any expense or loss for labor, supplies, rental machinery or for any other reason.

No other warranty of any kind whatsoever, express or implied, is made with respect to this sale; and all implied warranties of merchantability and fitness for a particular purpose which exceed the obligations set forth in this written warranty are hereby disclaimed and excluded from this sale.



# Parts Illustration

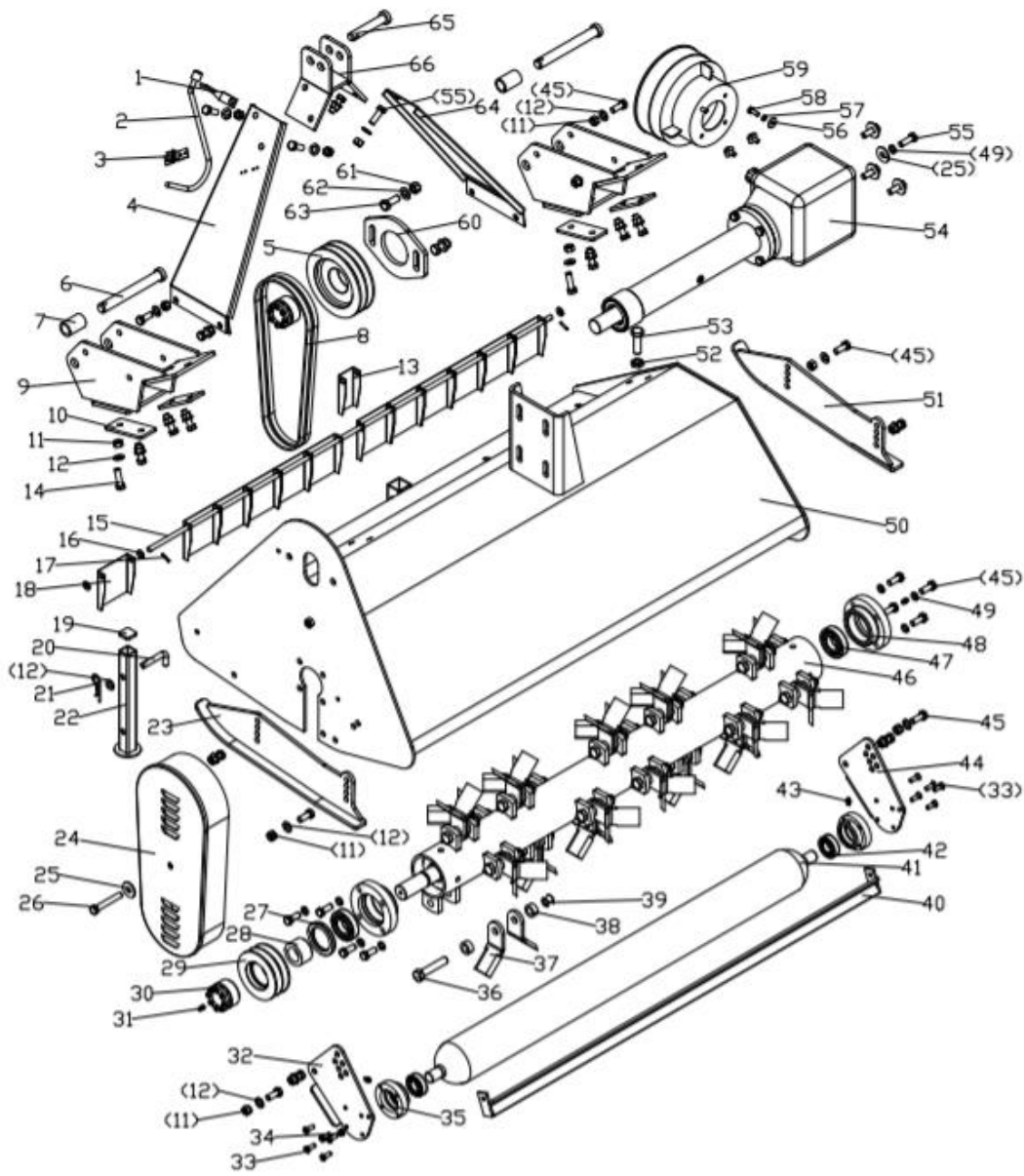

REF	PART NUMBER	DESCRIPTION	QTY
1	EFGC125. 101	Fixing plate	1
2	EFGC125. 124	Hook	1
3	EFGC125. 102	Clamp for hook	2
4	EFGC125. 021	Suspension plate (R)	1
5	EFGC125. 121	Big belt pulley	1
6	EFGC125. 109	Pin shaft weldment	2
7	EFGC125. 108	Spacer	2
8	GB/T1154-97/A965	Strap SPB991	2 (EFGC125)
			2 (EFGC105)
			3 (EFGC145)
			3 (EFGC155)
			3 (EFGC165)
			4 (EFGC175)
9	EFGC125. 013	Hanging weldment	2
10	EFGC125. 103	Splint	4
11	GB6184-86/M12	Locking nut M12	24
12	GB97. 1-85/12	Plain washer 12	40
13	EFGC125. 114	Fender	1
14	GB5783-86/M12X40	Bolt M12x40	8
15	EFGC125. 104	Shaft for fender	1
16	GB97. 1-85/10	Plain washer 10	17 (EFGC125)
			15 (EFGC105)
			19 (EFGC145)
			20 (EFGC155)
			21 (EFGC165)
			22 (EFGC175)
17	GB879-86/4X22	Elastic cylindrical pin 4x22	2
18	EFGC125. 113	Fender	12 (EFGC125)
			10 (EFGC105)
			14 (EFGC145)
			15 (EFGC155)
			16 (EFGC165)
			17 (EFGC175)
19	EFGC125. 112	Cover	1
20	IG135. 00. 107	Bent pin	1
21	EFGC125. 110	R pin	1

23	EFGC125. 014	Base plate (L)	1
24	EFGC125. 012	Belt cover	1
25	GB96-85/12	Plain washer 12	5
26	GB5782-86/M12X80	Bolt M12x80	1
27	GB13871-94/55X80X8	Oil seal FB55X80X8	1
28	EFGC125. 116	Oil-sealing sleeve	1
29	EFGC125. 117	Small belt pulley	1
30	JB/T7934Z3/35X60	Swellable sleeve	2
31	GB1152-89/M8X1	Oil cup M8X1	2
32	EFGC125. 105	Supporting for roller (R)	1
33	GB2673-86/M8X25	Hex head bolt M8X25	10
34	GB6184-86/M8	Locking nut M8	2
35	EFGC125. 107	Bearing	2
36	GB5782-86/M16X1. 5X85	Bolt M16x1.5x85	20 (EFGC125)
			16 (EFGC105)
			24 (EFGC145)
			24 (EFGC155)
			28 (EFGC165)
			28 (EFGC175)
37	EFGC125. 122	Blade	40 (EFGC125)
			32 (EFGC105)
			48 (EFGC145)
			48 (EFGC155)
			56 (EFGC165)
			56 (EFGC175)
38	EFGC125. 119	Sleeve	40 (EFGC125)
			32 (EFGC105)
			48 (EFGC145)
			48 (EFGC155)
			56 (EFGC165)
			56 (EFGC175)
39	GB6184-86/M16X1. 5	Locking nut M16X1.5	20 (EFGC125)
			16 (EFGC105)
			24 (EFGC145)
			24 (EFGC155)
			28 (EFGC165)

41	EFGC125. 017	Roller weldment	1
42	UC205	Flange UC205	2
43	GB1152-89/M6	Oil cup M6	2
44	EFGC125. 106	Supporting for roller (L)	1
45	GB5783-86/M12X30	Bolt M12x30	23
46	EFGC125. 018	Blade axle weldment	1
47	UC207-Z	Flange UC207-Z	2
48	EFGC125. 115	Bearing	2
49	GB93-87/12	Spring washer 12	12
50	EFGC125. 011	The cover weldment	1
51	EFGC125. 015	Base plate (R)	1
52	GB6173-86/M16x1. 5	Nut M16x1.5	1
53	GB5786-86/M16X1. 5X50	Bolt M16X1.5X50	1
54	EFGC125. 019	Gearbox assembly	1
55	GB5783-86/M12X35	Bolt M12x35	5
56	GB96-85/8	Plain washer 8	4
57	GB93-87/8	Spring washer 8	4
58	GB5783-86/M8X20	Bolt M8x20	4
59	FM150. 120	Guard shade	1
60	EFGC125. 120	Tension plate	1
61	GB6184-86/M14	Locking nut M14	2
62	GB97. 1-85/14	Plain washer 14	2
63	GB5783-86/M14X35	Bolt M14x35	2
64	EFGC125. 023	Suspension plate (L)	1
65	EFGC125. 123	Pin shaft	1
66	EFGC125. 022	Bracket weldment	1

## Gearbox Assembly

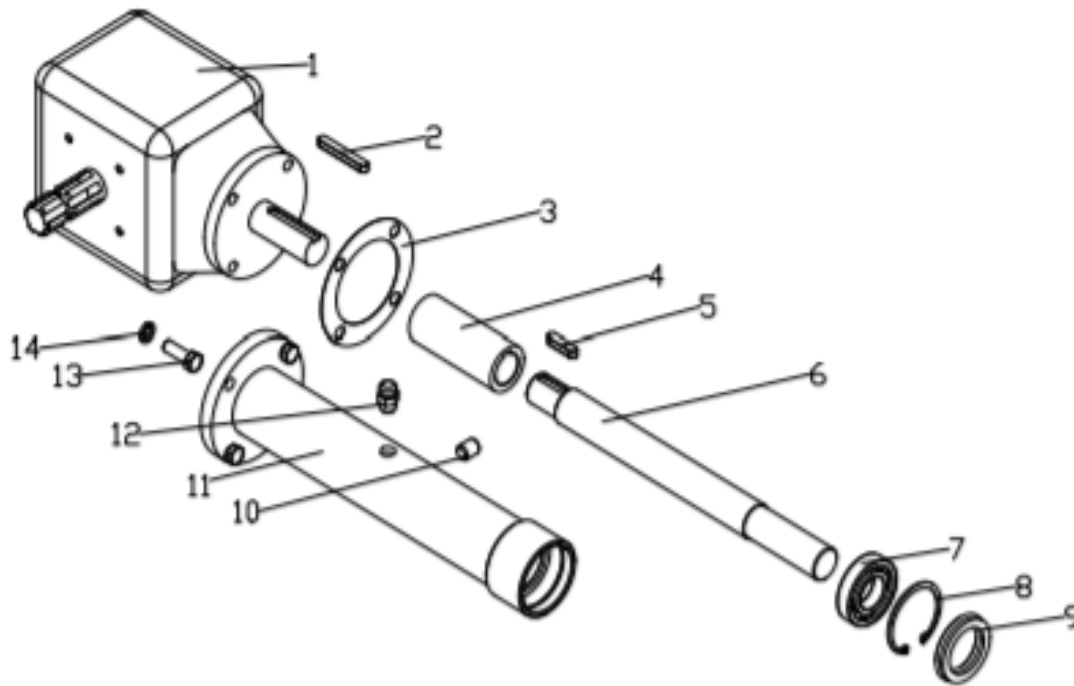

REF	PART NUMBER	DESCRIPTION	QTY
1	XH50. 300Z. 02	Gearbox assembly	1
2	GB1096-79/A10X70	Key A10X70	1
3	EFGC125. 166	Paper gasket	1
4	EFGC125. 167	Connected sleeve	1
5	GB1096-79/A10X40	Key A10X40	1
6	EFGC125. 168	Shaft	1
7	GB/T276-94/6207	Bearing 6207	1
8	GB893. 1-86/72	Circlip 72	1
9	GB13871-94/35X72X10	Oil seal 35x72x10	1
10	ZBT 32001. 3-87	Retainer	1
11	EFGC125. 020	Shaft tube weldment	1
12		Bolt of plug screw M16X1. 5	1
13	GB5783-86/M12X35	Bolt M12X35	4
14	GB93-87/12	Spring washer 12	12