

Construction Equipment

DOOSAN

SD200
SD300
SD300H



Powered by **Innovation**

Certain specification(s) are based on engineering calculations and are not actual measurements. Specification(s) are provided for comparison purposes only and are subject to change without notice. Specification(s) for your individual Doosan equipment will vary based on normal variations in design, manufacturing, operating conditions, and other factors. Pictures of Doosan units may show other than standard equipment.

DOOSAN

Hyundai Doosan Infracore

489 Injung-ro, Dong-gu, Incheon, South Korea

<http://global.doosanequipment.com>

DIPBE-00-2211

Hyundai Doosan Infracore is an affiliate of Hyundai Heavy Industries Group.
The Doosan trademark, **DOOSAN**, is used under license from Doosan Corporation.

Photos may include optional equipment

Powered by **Innovation**

SD200

SOLID-BASED, SPORTY PLAYER

BALANCED POWER, TUNED EFFICIENCY

- Ideal operating speed and 40-degree steering angle, sharply improve work efficiency.
- SD200 armed with stronger breakout force and tractive force, reflecting its excellent performance in a high-load working environment.

BUILT FOR ALL CONDITION

- Reasonable matched technology, ensures a more reliable and durable equipment.
- Industry leading cooling system, guarantees continuous and uninterrupted work under high temperatures.

ALL AROUND SAFETY AND COMFORT

- Noise reduction technology complying with international standards provides protection and boosts work efficiency.
- Newly designed cabin is spacious and provides wider view and enhanced comfort.



SD200 CERTIFIED PERFORMANCE



ENGINE (WP6G125E22)

The perfect blend of efficiency and power. The Weichai engine produces 92 kW at 2,200 rpm. High power and appropriate torque range enables to precisely deliver the stable working speed.

SD200 REINFORCED DURABILITY

SOLID FRAME STRUCTURE

3D CAD and FEM technologies are adopted in the analysis of technical design. Improving the strength, durability and reliability of the device.

PROVEN DURABILITY

SD200's working attachments and articulated pin are properly matched in size and are optimally positioned in force bearing area.

TRANSMISSION SHAFT

Double bearing supporting propeller shaft in dual configuration improves machine's reliability. Lubricating oil can be infused easily, enhancing the durability.

ALUMINUM RADIATOR

SD200 used aluminum radiator, which is stronger and guarantees better quality than copper, enhancing the machine reliability.

COOLING PERFORMANCE

The patented cooling system offers continuous and uninterrupted work under high temperatures.

EASY MAINTENANCE

ENGINE COVER

Engine cover part is integrated in one-piece. United cover makes it easy to repair engine and sub parts.

EASY APPROACH

Both sides of the hood can be opened to the side. Making daily oil inspection and maintenance works quicker and more convenient.

CONVENIENT INSPECTION ON HYDRAULIC LEVEL

Monitoring the hydraulic oil level was made easier, to reduce maintenance time and to improve device service lifetime.

QUICKLY CHANGEABLE BREAK DISCS

The use of quick-change brake discs allows the user to check brake pads for excessive wear at any time and change the brake pads more easily without removing the tires.

HIGHLY EFFICIENT COOLING FAN

The cooling fan made up of varied sized blades, efficiently reduces noise and increases air flow.

OUTDOOR POWER SWITCH

To enhance maintenance safety and convenience, power switch is equipped on outdoor to cut off battery power when needed.



SD200 WELCOMING AND PERSONAL SPACE

CABIN COMFORT

Ample space, wide visual field and intuitive features will guarantee a pleasant work. Noise inside cabin is lower, comfortable working space with multi angle adjustable steering wheel.

AIR FLOW INCREASED BY 30%

Offering high-performance air conditioning system, electronically controlled according to the environmental conditions.

NEW OPERATOR PANEL

The new instrument gauge panel has been changed simple and intuitively to put essential information right in front of the operator.

ERGONOMICALLY DESIGNED PEDAL

The adjusted pedal angle relieves the pressure on ankle and joints, reducing operator's fatigue.

LED LAMP FOR IMPROVED VISIBILITY

Existing front lamp has been upgraded to LED and totally six more lights have been added. Two additional LED lights and cables on the front and four more on the back.



TECHNICAL SPECIFICATION (SD200)

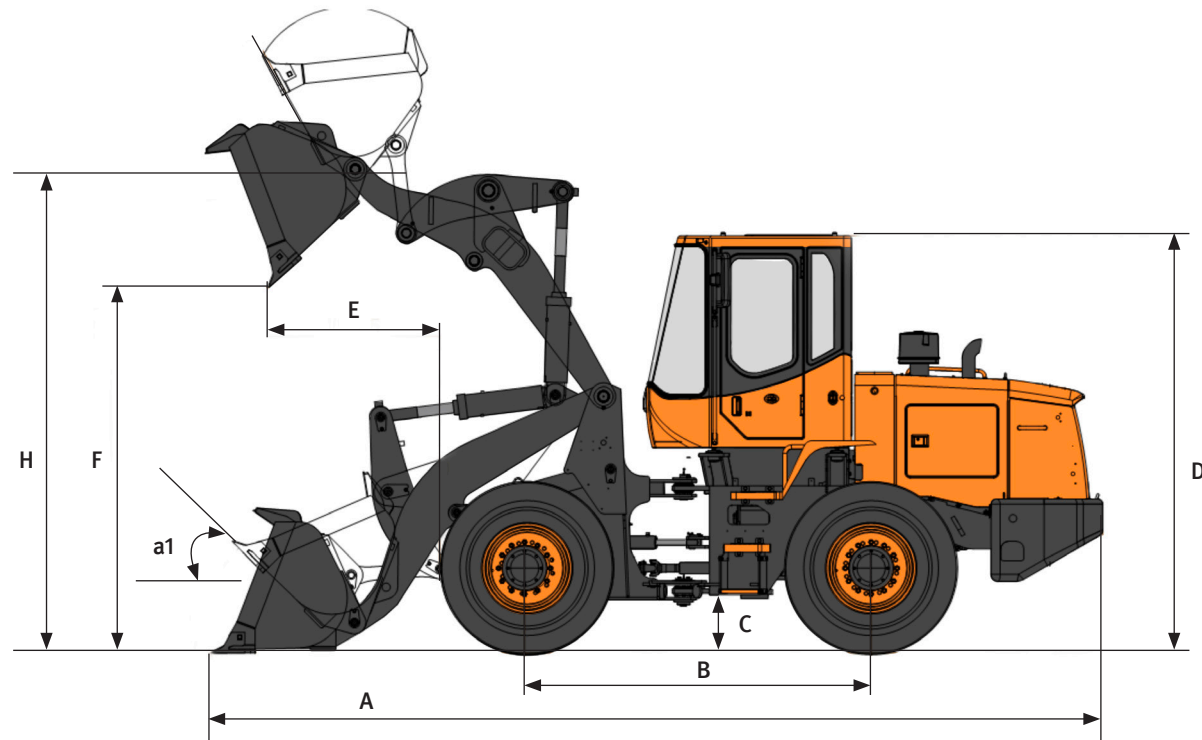

ENGINE

Model	Weichai WP6G125E22 (TIER 2)
Rated Power (SAE J1995 Gross)	92 kW (125 ps) @ 2,200 rpm
Max. Torque (SAE J1995 Gross)	500 N.m @ 1,400~1,500 rpm
Number of cylinders/bores/strokes	6 / 105 mm / 130 mm
Displacement	6.7 L

TRANSMISSION

Type	4 Speed, Power-shift, Countershaft, engine remote mounted with propeller shaft & damper
Torque Converter Stall Ratio/Size	3.2 / 315 mm

HYDRAULIC SYSTEM

Main Pump Type	Fixed gear
Main Pump Displacement	100 cc/rev
Max. Flow Rate	215 l/min

GENERAL SPECIFICATIONS

Operating Weight	10.4 ton
Bucket Capacity (SAE HEAPED)	1.7 m ³
Payload	3 ton
Travel Speed (1/2/3/4)	8.5 / 13.0 / 24.0 / 37.0 km/h
Static Tipping Load (straight)	8,000 kg
System Pressure (Work/Steer)	170/140 kg/cm ²
Sound Level in CAB (2000/14/EC)	84 dB (A)
External Sound Power Level (2000/14/EC)	112 dB (A)
Fuel Tank Capacity	150 L
Tire Size	17.5 - 25 - 12 PR

DIMENSIONS & WORKING RANGE (SD200)

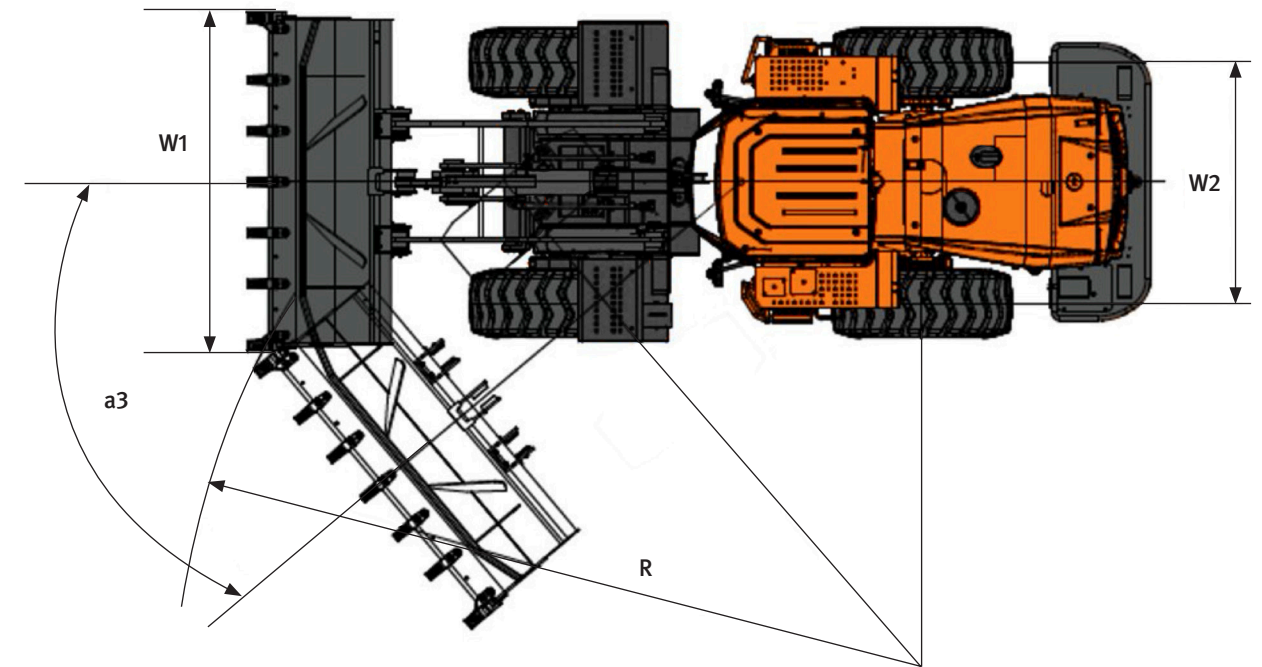

ITEMS		UNIT	STD.	OPT 1	OPT 2	OPT 3	
Operating Weight		ton	10.4	10.5	10.6	10.6	
Bucket Capacity (SAE HEAPED)		m ³	1.7	1.7	2.2	2.2	
Arm			STD.	LONG	STD.	STD.	
Breakout Force		kN	99				
Dimension	Overall Length	A	mm	6,950	7,138	7,007.5	7,165
	Overall Width	W1	mm	2,496	2,496	2,496	2,496
	Overall Height	D	mm	3,350	3,350	3,350	3,350
	Ground Clearance	C	mm	350	350	350	350
	Wheelbase	B	mm	2,830	2,830	2,830	2,830
	Tread	W2	mm	1,850	1,850	1,850	1,850
	Working Range	Dump Height at 45° (with tooth)	F	mm	2,815	3,109	2,775
Dump Reach at 45° (with tooth)		E	mm	1,195	1,066.5	1,186	1,057
Max. Tilt Angle (on ground)			degree (°)	45	45	45	45
Max. Tilt Angle (at fully raised)			degree (°)	61	60	63	60
Height at bucket pivot point		H	mm	3,740	4,028	3,740	4,028
Max. Tilt Angle (at carry)		a1	degree (°)	50	50	50	50
Digging Depth (0° level)			mm	55	72	54	42
Max. Steering Angle		a3	degree (°)	40	40	40	40
Turning Radius (tire center)			mm	5,090	5,090	5,090	5,090
External radius at bucket edge		R	mm	5,710			
Gradeability		% (°)	58 (30)				